

SCHEMATIC CIRCUIT - HERCULES IRS

HOSES	LENGTH (mm.)
H1	1000
H2	1000
H3	2000
H4	2000
H5	9000 X 4
H6	9000 X 4
H7	9000 X 3
H8	9000 X 3
H9	3500 X (R2-3/4)
H10	3500

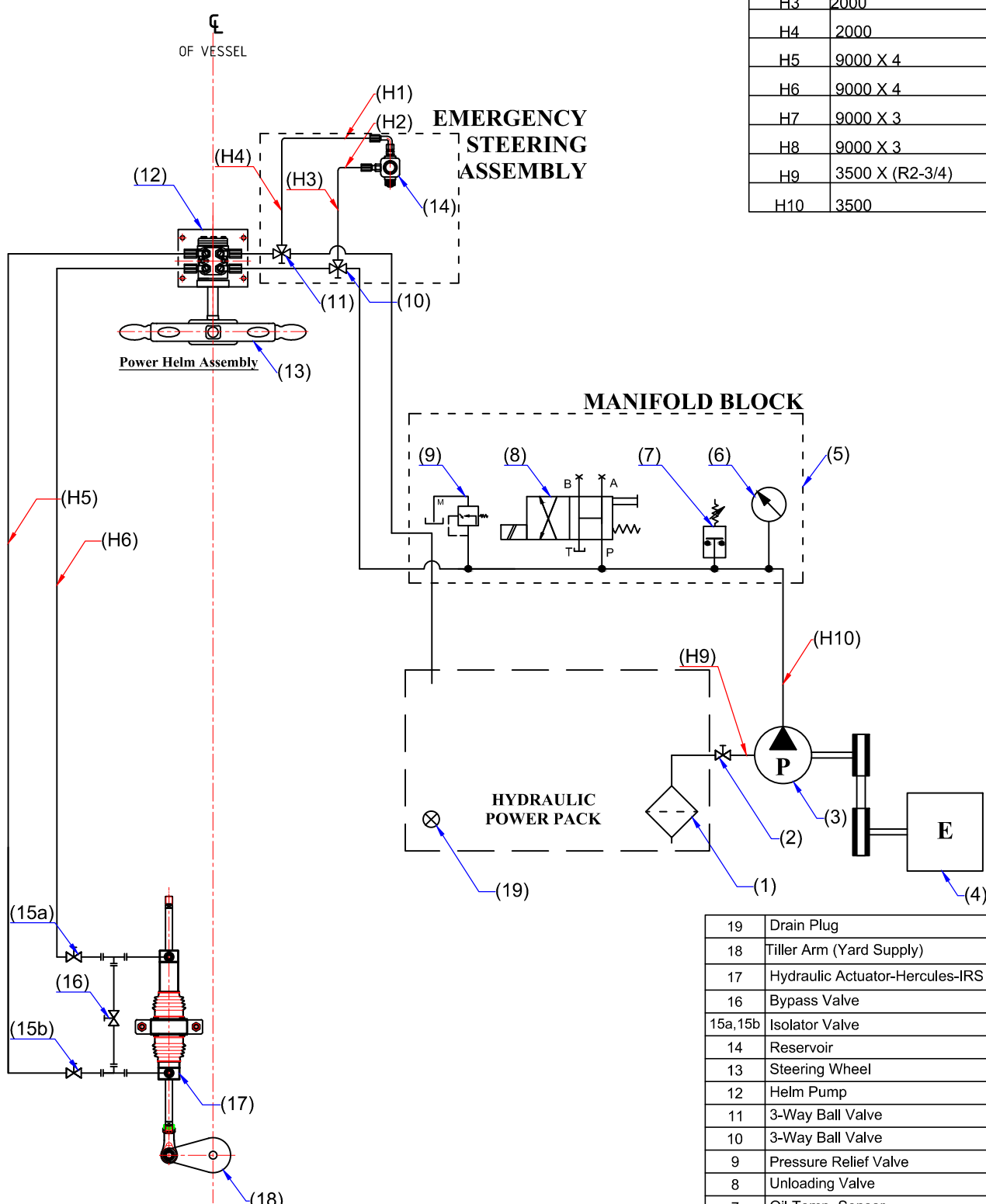

19	Drain Plug
18	Tiller Arm (Yard Supply)
17	Hydraulic Actuator-Hercules-IRS
16	Bypass Valve
15a,15b	Isolator Valve
14	Reservoir
13	Steering Wheel
12	Helm Pump
11	3-Way Ball Valve
10	3-Way Ball Valve
9	Pressure Relief Valve
8	Unloading Valve
7	Oil Temp. Sensor
6	Pressure Gauge
5	Hyd.P.P.Tank
4	Engine
3	Hydraulic Pump
2	2-Way Ball Valve
1	Suction Strainer
Sl. No.	Description

REVISION - (A) : 1. One Bypass Valve & Two Isolation Valves has been added (16.08.2024).



**MAC ♦ N ♦ HOM SYSTEMS
KOCHI - 20**

DESIGNATION

SCHEMATIC CIRCUIT DIAGRAM
HERCULES - IRS

DWG. No.

MHS-4157A

DATE

16.08.2024